

Modular Belt Conveyors

Identify. Create. Resolve.



IBS has expanded its Belt Conveyor offering to include a range of economical Modular Belt Conveyors.

IBS's Modular Belt Conveyor are designed in fixed section lengths and belt widths to reduce delivery lead times, installation times with spare parts inventory and reduce your Total Cost of Ownership. IBS's Modular Conveyors are manufactured in line with the outstanding quality of our custom built conveyors that our clients have come to expect.

Standard modules are in 3m sections, with a shorter, custom module to ensure the conveyor suits your plant layout. Head and tail sections are designed to cover a wide range of throughputs for each belt size. They can be used in horizontal and inclined applications – support legs can be positioned as required. All conveyors can include covers.

A typical application is for narrow belt width, fully enclosed modular sample and dust return conveyors. All of our conveyors can be designed for Modularisation and our Standard belt widths include 350mm, 450mm and 750mm.

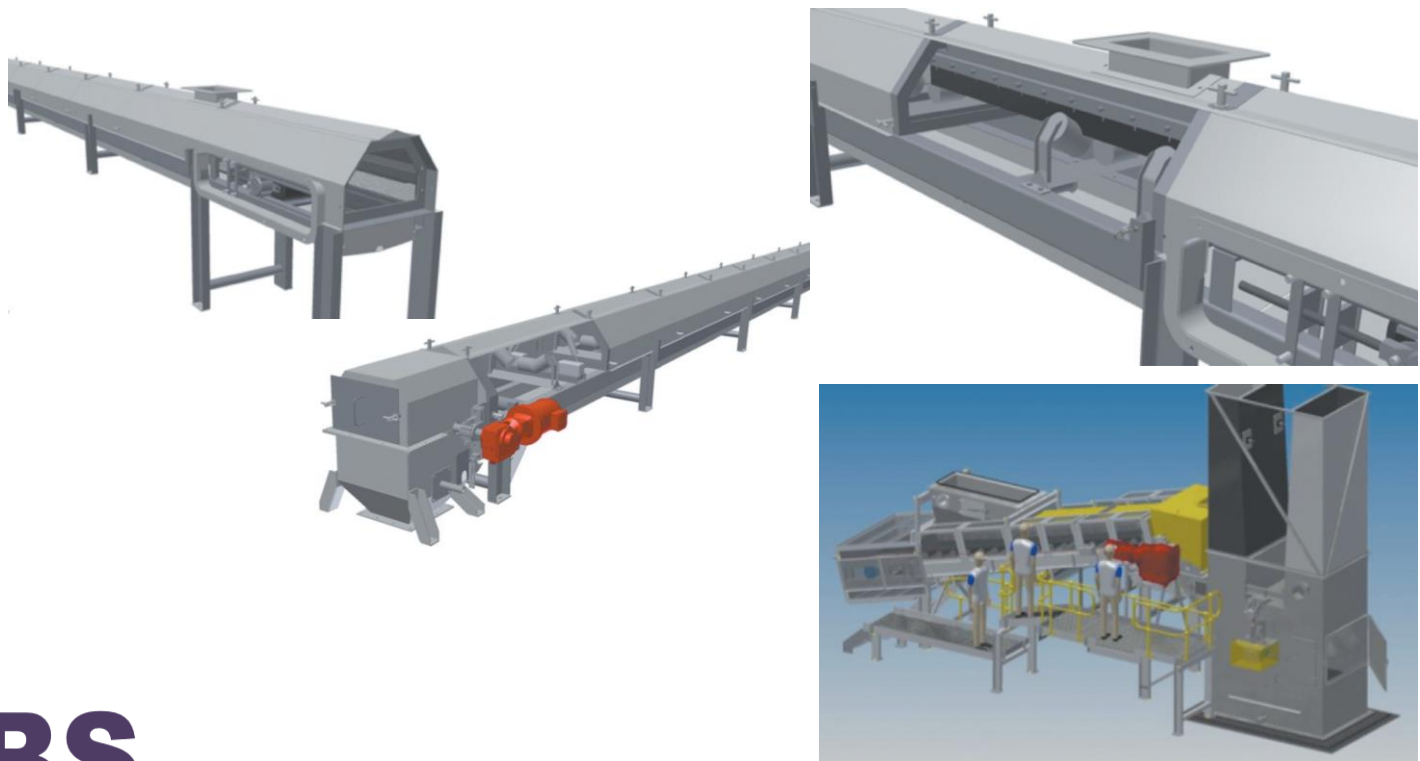

IBS

BULK HANDLING PTY LTD

Ask us how we can improve your processes today.

IBS Bulk Handling Pty Ltd

Unit 205/75 Tulip St,
Cheltenham Victoria, Australia 3192

Tel: +61 3 9585 6391

Fax: +61 3 9585 4349

info@ibsbulkhandling.com.au

www.ibsbulkhandling.com.au

IBS China

Rm. No.413, Shouxi International Building,
No.6 Wenchang Middle Rd.,
Yangzhou City,
China-225003

Tel: +86-514-82065058

Fax: +86-514-82065058

IBS Thailand

Unit 2901-2904, Level 29,
388 Exchange Tower, Sukhumvit Road,
Klongtoey Subdistrict, Klongtoey District,
Bangkok, Thailand 10110

Tel: +66 0 2 104 9272

Fax: +66 (0) 2 104 9101